

## VersaTack Universal Power Supply — Basic Configurations

Hurlertron's VersaTack is a 30KV supply that can be configured for dual or single polarity, two (2) output jacks per polarity, and front or back mounted output jacks, as well as an optional remote operator control.

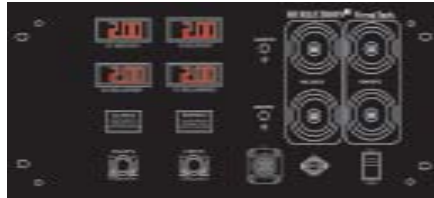

VersaTack dual power supply with HV sockets on front panel.



VersaTack single polarity negative power supply with HV sockets on front panel.



VersaTack single polarity positive power supply with HV sockets on front panel.



VersaTack dual polarity power supply with HV sockets on the rear panel.

### HSP Style High Voltage Cable for H-QD Charge Bars

The Hurlertron Inset Style Plug (HSP) is compatible with the DPS-95, DPSV30, Model 2577 and Model 2077, as well as the new VersaTack Power Supply. The cable connects to HQD, HSC and the Round bar using our standard quick disconnect.



### ESP Style High Voltage Cable for H-QD Charge Bars

The Hurlertron Extended Style Plug (ESP) is compatible with the HVG30/5H and the Model 777 Power Supplies, and the new VersaTack Power Supply can be configured to maintain compatibility. The cable connects to HQD, HSC and the Round bar using our standard quick disconnect.



May 2004



1820 Tempel Drive, Libertyville, IL 60048  
847.680.7022 Fax 847.680.7338 • [www.hurlertron.com](http://www.hurlertron.com)

# VersaTack

## Electrostatic Pressroom Tacking

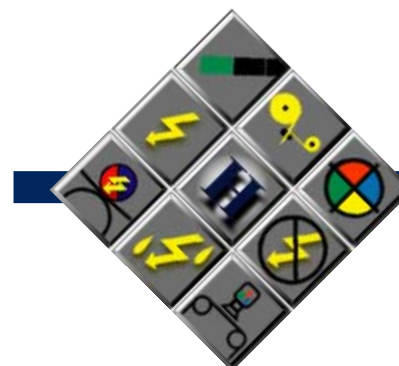

**Ribbon Tacking** is the process of applying a positive and negative charge to opposite sides of the ribbon stretch. The resulting elimination of air pockets produces a temporary adhesion that reduces (and in many cases eliminates) dogears and ribbon weave.

In a typical application, mount bars with approximately 1-1/2 inches between emission points on the positive and negative bars. The bars should be equal distances from the ribbons.

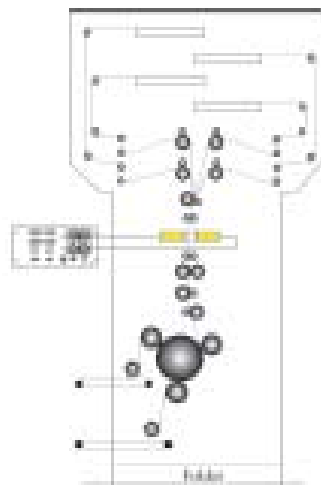

**Chill Roll Tacking** refers to a controlled electrical charge applied to a moving web causing the charged web to be attracted to the chill roll. This reduces the air gap between the web and the roll surface, which in turn reduces solvent condensation on the roll to eliminate roll streaking.

If reduced press speeds are required to eliminate streaking, roll tacking allows speed increases up to 20%; within the limits of press capability.

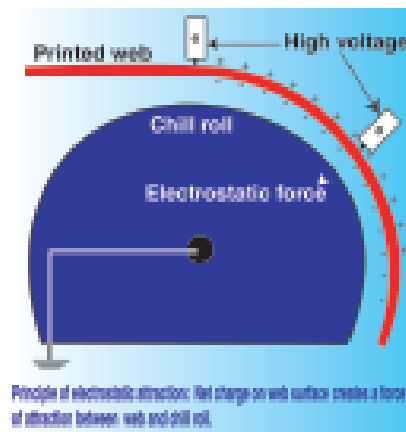

Other roll tacking applications include:

- **Nipless Trolley** on printing presses - Eliminate mechanical nips.
- **Web Guide Tacking** - Enhance steering control by eliminating web "lift off".
- **Chill Roll Tacking** - Improve cooling on any substrate or process that uses chill rolls including plastics, films, laminates, etc.
- **Dryer Idler Roll Control** - Control web weave in long dryer runs.

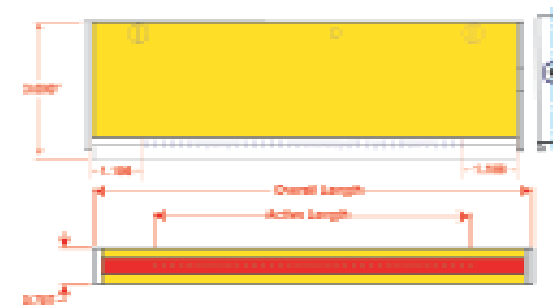

### Hurlotron Super Charger (HSC)

In applications that require the addition of a second bar of each polarity to achieve acceptable performance, Hurlotron's new Super Charger (HSC) provides the effect of two charge bars in one by placing two rows of active pins within its width, one inch apart.

### Hurlotron Quick Disconnect (HQD)

For many common applications, Hurlotron's standard H-QD Charge bar will provide sufficient tacking, and can be built to many customer-specified lengths.

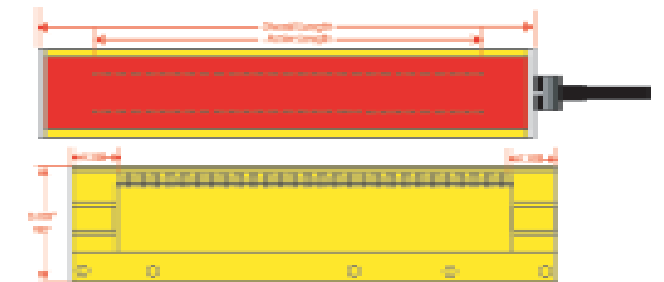

### Specialty Applications

#### Hurlotron H-QD 8-Pin "Round" Bar

Hurlotron's Round Electrostatic Charging "Bar" provides the tacking power of two (2) side-by-side 4-pin resistors. The bar is particularly useful in spot tacking applications, edge pinning applications, card tacking applications and in many other applications where bar mounting space is extremely constrained. The round bar can be used with all Hurlotron tacking power supplies and is compatible with the new quick disconnect cables.

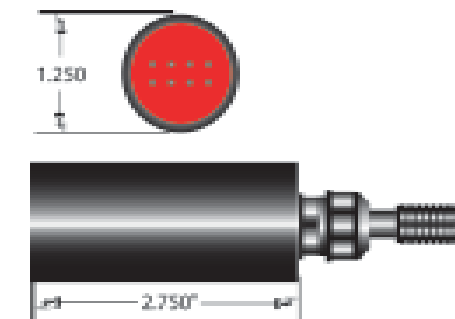

#### Bars for FM Approved Systems (Tacking in a hazardous area)

Hurlotron has developed an electrostatic tacking system configuration that has been tested and approved by Factory Mutual for use in a hazardous area. Under FM Approved specifications, the cable must be potted to the bar, must be 7' long and must have Hurlotron's inset style high voltage plug illustrated on the back of this brochure.

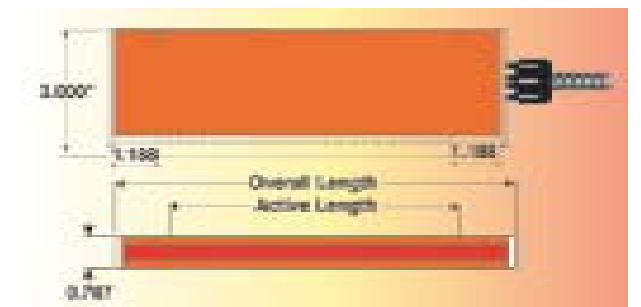

#### Active Antistatic Systems are required in some chill roll tacking operations.

1. *If the web is a particularly effective insulator as with heavy ink coverage, heavy substrates, substrates with filters, calendered substrates, etc., it will limit dissipation through the web to the chill roll surface. A dry atmosphere around the chill unit also makes the web a much better insulator.*
2. *The laminar air layer carried with the web as it exits the dryer contains significant amounts of evaporated solvents. Chill units designed to remove the laminar layer of air wrap the web around the first chill roll and mount the second chill roll so the web surface passing over the second chill roll comes very close to the web entering the first chill roll. This type of chill stand, when chill roll tacking is applied, becomes an uncontrolled static generator limited only by the maximum amount of charge the web will hold. These applications must use active antistatic systems in conjunction with chill roll tacking.*